



CLSA Australia Pty Ltd

Crossing System User Guide (Non-Public)

Contents

1	Summary.....	4
1.1.	Introduction.....	4
1.2.	Requirements users must adhere to prior to using CLSA's crossing system.....	4
2	CLSA's Crossing System.....	5
2.1	Overview of CLSA's Crossing System.....	5
2.2	Users of ALP Australia.....	5
2.3	Opt-out Arrangements.....	6
2.4	Supported Securities.....	7
2.5	Aggregation and Other Crossing Systems.....	7
2.6	Crossing Sessions.....	7
2.7	Order Routing Execution Methodology and Transaction Pricing.....	8
3	Crossing Rules.....	16
4	Order Types.....	16
5	User Treatment.....	17
6	Anonymity.....	17
7	CLSA Principal Flow.....	17
8	Liquidity Providers.....	17
9	Fees.....	17
10	Crossing Suspension.....	18
11	Crossed Trade Indicator.....	18
12	Resilience.....	19

13	Outages.....	19
14	Disclosures.....	20
15	Other Dealing Matters.....	21
15.1	Fair and orderly operation	21
15.2	Order confidentiality	21
16	Risk Disclosure Relating to the use of the crossing system	21

1 Summary

1.1. Introduction

CLSA Australia Pty Ltd (“**CLSA**”) is a market participant governed by the obligations set out in the ASIC Market Integrity Rules (Securities Markets) 2017 (“**the Rules**”).

CLSA’s crossing system is a certified Automated Order Processing System subject to the requirements set out in Part 5.6 of the Rules, which govern AOP filters, conduct and infrastructure and also Chapter 5A of the Rules which governs the operation of crossing systems in Australia.

CLSA’s crossing system, (hereafter referred to as “**ALP Australia**”, is a continuous and anonymous order matching and automated trade reporting system which seeks to cross buy orders with sell orders, and automatically report successful cross trades which satisfy the ‘Trade with Price Improvement’ criteria in accordance with 6.2.3 of the Rules.

The purpose of this document is to provide the requisite disclosure information to clients who are “users” of the ALP Australia in accordance with 5A.2.2 of the Rules.

1.2. Requirements users must adhere to prior to using CLSA’s crossing system

Prior to routing orders to ALP Australia, users are advised to review the information contained in this document.

In accordance with 5A.2.2 of the Rules CLSA is required to provide the details contained in this document entitled “Crossing System User Guide (Non-Public)” before accepting orders for the first time and prior to accepting any orders from clients after updates have been made to this document which contains the relevant details of changes to the operation of ALP Australia. The latest version of this document is available at the Direct Market Access/Electronic Trading section of our website, at clsa.com/terms-of-business/. This document is subject to change from time to time.

2 CLSA's Crossing System

2.1 Overview of CLSA's Crossing System

ALP Australia commenced operation on 15 October 2021 and is registered with ASIC under crossing system identifier code '2311'. The function of ALP Australia is to cross opposing orders and provide an improved executed price when comparing the National Best Bid and Offer ("NBBO") spread displayed on ASX Ltd ("ASX") and Cboe Australia Pty Ltd ("Cboe") during continuous trading.

Trades are reported as NBBO crossing to ASX as the default reporting Market/exchange. However, in the event ASX is unable to accept trade reports due to technical difficulties, ALP Australia has the ability to switch trade reporting to Cboe.

ALP Australia does not publish information regarding its order book to any other CLSA group trading desk or to any other market participant.

The crossing system is intended for use via the following mechanisms:

- CLSA's internal traders have the option to route their client orders, or parts of those orders through CLSA's crossing system and/or external Crossing Systems, before they are sent to the exchanges.
- CLSA's Direct Market Access ('DMA') clients have the option to directly route orders, or parts of those orders through CLSA's crossing system and/or external Crossing Systems, before they are sent to the exchanges.

2.2 Users of ALP Australia

CLSA is licensed to provide financial services to Wholesale Clients in accordance with s761G (4) of the *Corporations Act 2001*. As such, users, which access ALP Australia via CLSA's algorithmic trading system, are all classified as 'Wholesale'. There is no Retail client participation in ALP Australia.

A "user" or "client" means a Wholesale Client whose orders are placed into or, whose transactions are conducted in the crossing system, and includes any qualified investor who/which is ultimately responsible for originating the instruction in relation to an order placed into, or a transaction conducted in CLSA's crossing system.

User Tier Settings:

ALP Australia recognises a set of pre-defined tiers and each client user is designated to a specific tier based on the type of order flow from the client as set out in the table below:

Designated Tier Value in Crossing Engine	User Tier Name	Definitions
I	Institutional	A fund manager which is an Institutional Professional Investor
L	Liquidity Provider	An Institutional Professional Investor which engages in high frequency trading
B	Broker Dealer	A regulated broker dealer
A	Alternative Liquidity Pool/ Aggregator	An ASIC regulated crossing system in Australia

Each client can choose the crossing preference for their orders i.e. to cross with the orders from clients belonging to a particular tier or group of tiers.

Example: A Liquidity provider client ("L") can choose to cross only with Institutional ("I") and Broker Dealer ("B") orders. Crossing Engine will cross the client orders only with the orders from clients belonging to "I" and "B" tiers.

Client Exclusion:

A client can restrict their orders from interacting with the orders from a client or list of clients irrespective of the tier they belong to.

Example: A Liquidity provider client ("L") who is willing to cross with Broker Dealer ("B") orders, can still restrict their orders from crossing with a specific "client/clients" orders belonging to "B" tier.

2.3 Opt-out Arrangements

ALP Australia is available to all CLSA clients, unless a user has specifically requested to opt out of ALP Australia. .

For clients using ALP Australia, unless instructed otherwise, default client settings will be set to interact with all user tiers. However, clients may also 'opt out' of any particular user tiers.

To opt-out of routing their orders to ALP Australia (and/or a particular user tier group) provide written instructions to CLSA (including using the Opt Out nomination form) by e-mailing to 'clsa_alp_optout@clsa.com' or your relationship manager.

Clients may also opt-out particular orders by indicating such on the relevant FIX tag in the order message (please refer to the 'crossing indicator' table in section 2.7 of this document).

2.4 Supported Securities

The securities available on ALP Australia are:

- Equity Market Products Traded on ASX and Cboe.

2.5 Aggregation and Other Crossing Systems

CLSA may route your orders to external crossing systems, as specified in CLSA's Crossing System Information (Public Disclosure), which is available at the Direct Market Access/Electronic Trading section of our website, at clsa.com/terms-of-business/.

Each external crossing system is operated and managed by the relevant external operator as set out at the "Crossing systems registered with ASIC" website: (<https://asic.gov.au/regulatory-resources/markets/market-structure/crossing-systems-registered-with-asic/>) and not by CLSA.

ALP Australia may also receive orders from crossing system operators and aggregators as specified in CLSA's Crossing System Information (Public Disclosure).

2.6 Crossing Sessions

ALP Australia operates during the continuous trading hours of the ASX and Cboe. ALP Australia will not operate during the pre-open session, closing auction, or any period that is not deemed as continuous trading by ASX and Cboe.

ALP Australia will cease crossing orders fifteen seconds before the close of the morning continuous trading session, and fifteen seconds before the close of the afternoon continuous trading session to allow the crossing system sufficient time to report any crossed trades to the relevant

Market/ exchange before the trading session closes. In addition, ALP Australia will not start crossing orders until fifteen seconds after each session opens to avoid the volatility that is common at the exchange open.

These time-periods may be changed from time to time by CLSA.

2.7 Order Routing Execution Methodology and Transaction Pricing

Diagram 1 below illustrates the order flow between the client, CLSA's various trading systems and ALP Australia:

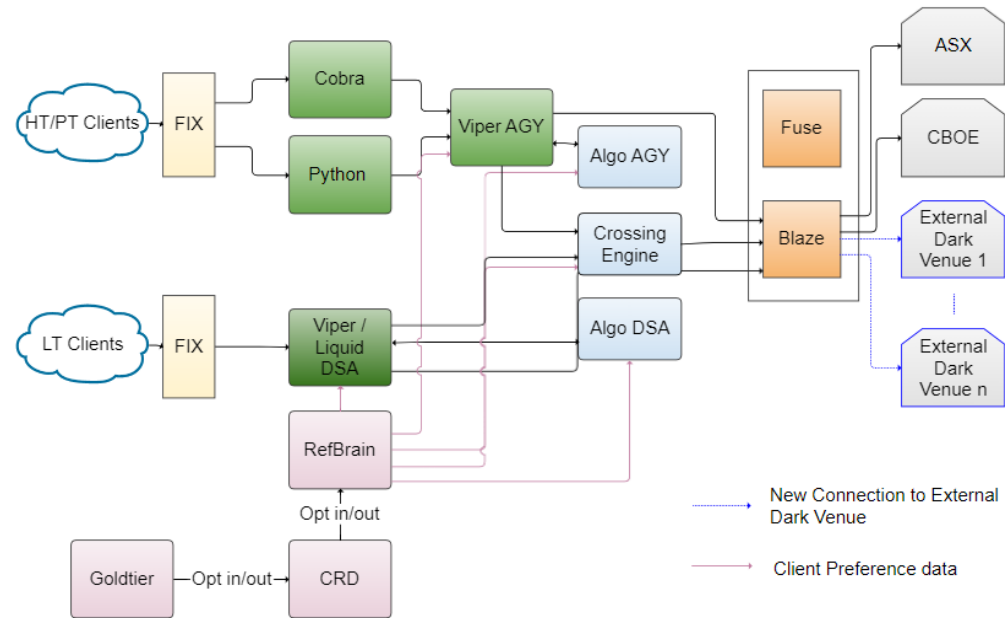

Crossing System Flows

CLSA's internal traders use a system named Viper to route orders to the exchanges. The orders are created in Viper either manually by the relevant trader, or electronically via a FIX message sent directly from the client's Order Management System. CLSA's execution traders typically split client orders into smaller slices, which may be sent directly to a trading venue (including the exchanges and their darkpools, ALP Australia or an external Crossing System – that the client has not Opted Out)

DMA clients send orders to CLSA's DMA system via their FIX enabled order management system. The FIX message will include an identifier to indicate whether the client would like the order to be sent directly to a trading venue (including the exchanges and their darkpools, ALP Australia or an external Crossing System – that the client has not Opted Out)

For clients who are unable to set this identifier, it will be defaulted to an agreed value on a per client basis, prior to the client being enabled.

Both internal traders, and external DMA clients, have the option to:

1. Bypass ALP Australia (or the client's external Crossing Systems), sending orders directly to the exchanges. These orders can only be matched on the exchange; or
2. Pass the order through ALP Australia (and/or the client's external Crossing Systems), then to the exchanges. These orders may be matched on either the exchanges, ALP Australia or an external Crossing System; or
3. Pass their orders to ALP Australia and/or to the client's external crossing systems.

Order Flow System Components

Viper

Viper is CLSA's internal order management and execution management system ('EMS'). All client orders are entered into Viper, either manually, or via FIX. CLSA uses separate instances of Viper for DMA flow and for agency flow to ensure the flows are segregated.

Viper Front End

Viper Front End is the graphical user interface for Viper. The Viper Front End is used by execution and sales traders to enter, route and monitor client orders.

Viper Database

The Viper Database is an oracle database used to store a record of all orders, trades and a complete history of all transactions that have been performed.

Algo

The Algo system is an algorithmic trading system. The Algo system interfaces with Viper for order management and routing. Users make use of the Viper front end to manage orders in the Algo system.

Real Time Prices

ALP Australia uses a 'real time' price feed.

CE Database

The CE Database is an oracle database used by CLSA's crossing system for persistence. This database maintains a record of the state of all orders that have been sent to, and all trades crossed in CLSA's crossing system.

ASX Blaze

ASX Blaze is a FIX server used to connect internal CLSA trading systems, Viper and CLSA's crossing system, to the ASX.

Cboe Blaze

Cboe Blaze is a FIX server used to connect internal CLSA trading systems, Viper and CLSA's crossing system, to Cboe.

Fuse

Fuse is the risk checking system used to validate all orders before they are sent to either the ASX or Cboe.

CLSA's Crossing System and Algo Engine Interaction

The Algo engine, which forms part of the order flow, it is independent of CLSA's crossing system. Traders may choose, on a per order basis, whether slices sent to the exchange via the Algo engine, will first pass through or a Crossing System.

The Algo engine views the client's accepted Crossing Systems as an executing destinations, similar to an exchange.

Crossing Mechanism

ALP Australia is a continuous order matching system. The order-matching algorithm operates under the following conditions:

1. A new order is received by ALP Australia;

2. The limit price of an existing order is amended; and
3. Periodically run the algorithm from a timer.

The order that initiates the algorithm will be termed the “initiator”.

The initiator will be one of the following:

1. The new order that has just arrived; or
2. The existing order that is being amended.

If the initiator is a buy order, then it will search through the list of existing sell orders for the same instrument. The search is conducted to ensure that the lowest priced sell orders are checked first. If there is more than one existing sell order at the same price, then they are searched in order of the time priority at which they arrived in ALP Australia at that price. This search algorithm will be known as “Price Time Priority”.

If an existing order is found with a limit price lower than or equal to the limit price of the initiator, then the two orders can match. The quantity of the match will be lower of either the initiator outstanding quantity, or the existing order outstanding quantity. The price of the match will be the limit price of the existing order.

If the initiator is a sell order, then it will search through the list of existing buy orders for the same instrument using the same Price Time Priority search algorithm described above, with the exception that higher priced orders will have priority over any lower priced orders.

When ALP Australia has determined that two orders can cross, the match is then subjected to a series of validations checks, as defined in section 10 of this document. The rules are executed sequentially. If any one of the rules fails, then the match is not performed. If the initiator is not matched with any existing orders, then it will be entered into ALP Australia’s internal order book (“IOB”) as an existing order, so it may match with any future initiators.

If all the crossing rules pass, ALP Australia can match both opposing orders with the match quantity, at the match price, as defined above. If either the buy or the sell order has been sent to the exchange, then the CLSA’s crossing system retrieves the match quantity back from the exchange, by either reducing, or cancelling the order. When the match quantity has been successfully retrieved from the exchange, ALP Australia sends a National Bid Best Offer (‘NBBO’) trade report to either the ASX or Cboe.

ALP Australia will only cross orders if the client tier of one order is in the cross tiers of the opposite order and vice versa.

ALP Australia will only cross orders if the client exclusion list of one order does not contain the client of opposite side order and vice versa.

Crossing Indicators

ALP Australia accepts a FIX tag on the order message, to indicate whether or not an order can be considered for crossing, and whether or not it should be sent to the exchange. Details are provided in the below table:

FIX Crossing Indicator	Meaning	Description
0	Do Not Cross	Do not cross the order, pass it through to ASX or Cboe.
1	Can Cross	Orders will route to ALP Australia, which will cross the order if there is a matching order or if the opportunity to cross with price improvement arises. If there is no immediate match, ALP Australia will route the order to the ASX/Cboe. If a cross is found within ALP Australia, the trade report will be sent to ASX (Cboe if ASX is unavailable)
2	Cross Only	Orders will route to ALP Australia only. Orders will not be routed to the ASX or Cboe under any circumstances for crossing. Orders will be crossed only if there is a matching order in ALP Australia which results in price improvement, under which circumstances the crossing will be executed and a trade report sent to ASX (Cboe if ASX is unavailable). Orders can be placed as Limit Orders or Market Orders (as applicable).
3	Cross Mid	Orders may be crossed in ALP Australia or be routed to the ASX/Cboe. If crossed in ALP Australia, the order crossing price will be an improvement when compared to the NBBO.
4	Cross Mid Internal	Orders routed to ALP Australia only. Orders will not be routed to the ASX/Cboe under any circumstances for crossing. The crossing price will be the mid-point between the NBBO.

Crossing Indicator Default

If the crossing indicator is not present on the new order FIX message received by ALP Australia, then ALP Australia will assume that the order is not to be crossed. It will be sent to the exchange, and it will not be stored in within the ALP Australia's IOB. This is the same behavior as setting the indicator to "Do Not Cross".

Pass Through Orders

If the crossing indicator is set to either 1 or 3, and the order cannot be matched on arrival in ALP Australia, it will be stored in ALP Australia's IOB, and then passed through to the relevant exchange. These orders shall be referred to as pass-through orders. If there are multiple pass-through orders in the IOB from the same client, consecutively, at the same price, then those orders will be matched in reverse time priority. This provides the best execution performance for that client, by maintaining those orders with the best queue priority on ASX or Cboe.

Dark Orders

If the crossing indicator is set to either 2 or 4, and the order cannot be matched on arrival in ALP Australia, then it will be stored in ALP Australia's IOB only, and will not be passed through to ASX or Cboe. These orders shall be referred to as dark orders. If there are dark orders and pass-through orders in the IOB from the same client consecutively at the same price, then dark orders will be matched with a higher priority than pass-through orders. This provides the best execution performance for that client, by maintaining those orders with the best queue priority on the exchange.

Crossing Examples

Initiator is a New Order with type 'Can Cross'

This example demonstrates the case where the matching algorithm is triggered based on a new order arriving.

Best Bid = \$5.00 Best Ask = \$5.01

10:40am	Order 1 received to buy 20K at \$5.005 as "Can Cross"
10:40am	ALP Australia cannot find a suitable matching order
10:40am	Order 1 is added to ALP Australia IOB
10:40am	Order 1 is sent to the exchange at \$5.00
10:45am	Order 2 received to sell 3K at \$4.95 as "Can Cross"
10:45am	ALP Australia finds Order 1 as a match
10:45am	Order 1 is reduced to 17K on the exchange
10:45am	An NBBO trade report for 3K at \$5.005 is sent to the exchange
10:45am	Both orders receive a trade of 3K at \$5.005

Initiator Order's Limit Price is Amended

This example demonstrates the case where the matching algorithm is triggered based on a limit price amendment for an existing order.

Best Bid = \$5.00 Best Ask = \$5.01

10:40am	Order 1 received to buy 20K at \$5.005 as "Can Cross"
10:40am	ALP Australia cannot find a suitable matching order
10:40am	Order 1 is added to ALP Australia IOB
10:40am	Order 1 is sent to the exchange at \$5.00
10:45am	Order 2 received to sell 3K at \$5.01 as "Can Cross"
10:45am	ALP Australia cannot find a suitable matching order
10:45am	Order 2 is added to ALP Australia IOB
10:45am	Order 2 is sent to the exchange at \$5.01
10:48am	Limit Price of Order 2 is amended to \$5.00
10:48am	ALP Australia finds Order 1 as a match
10:48am	Order 2 is cancelled from the exchange
10:48am	Order 1 is reduced to 17K on the exchange
10:48am	An NBBO trade report for 3K at \$5.005 is sent to the exchange
10:48am	Both orders receive a trade of 3K at \$5.005

Initiator is a New Order with type 'Cross Only'

This example demonstrates the case where the matching algorithm is triggered based on the periodic timer.

Best Bid = \$5.00 Best Ask = \$5.01
Day Low = \$5.01 Day High = \$5.25

10:40am	Order 1 received to buy 20K at \$5.005 as "Can Cross"
10:40am	ALP Australia cannot find a suitable matching order
10:40am	Order 1 is added to ALP Australia IOB
10:40am	Order 1 is sent to the exchange at \$5.00
10:45am	Order 2 received to sell 3K at \$4.95 as "Cross Only"

10:45am ALP Australia finds Order 1 as a match at price \$5.00
10:45am Cross Validation fails because day low is \$5.01
10:45am Order 2 is added to ALP Australia IOB

The two orders cannot cross because the match would violate the rules listed in Section 10. ALP Australia will periodically re-check if this match can occur once every 30 seconds.

10:46am Day Low = \$5.00 Day High = \$5.25

10:46am Periodic Cross Check finds a match between Order 1 and Order2
10:46am The day low price has moved to \$5.00, all cross rules pass
10:46am Order 1 is reduced to 17K on the exchange
10:46am An NBBO trade report for 3K at \$5.005 is sent to the exchange
10:46am Both orders receive a trade of 3K at \$5.005

The Periodic Cross Check runs once every 30 seconds. It re-checks any orders that previously failed the cross rules defined in section 10.

Intra-Spread Crossing

ALP Australia will only accept orders with limit prices that are aligned on an exchange tick boundary, or the mid-point price. The orders will be stored in its IOB at the price set by the client. If that price is not on a tick boundary, and the order cross indicator is set to "Can Cross", it will be rounded to a tick boundary before being sent to the exchange. Buy orders will be rounded down, and sell orders will be rounded up.

ALP Australia will store orders in its IOB with the price limited to at most four decimal places, since this is the maximum number of decimal places that can be reported to the ASX or Cboe on an NBBO trade report.

ALP Australia will only cross at the one of the following prices:

- i. Higher than the Best Available Bid and lower than the Best Available Offer by one or more Price Steps
- ii. the Best Mid-Point

3 Crossing Rules

- ALP Australia will only match orders between the National Best Bid/Offer price, at the time the match occurs.
- ALP Australia will only match orders between the day high and day low prices on the ASX, at the time the match occurs.
- ALP Australia will not cross any instrument that is suspended from trading on the exchange.
- The match price must have at most four decimal places.
- ALP Australia will not cross buy and sell orders from the same client (only trades which result in a change in beneficial ownership)

To ensure ongoing compliance with price-improvement requirements, CLSA undertakes the following:

- ALP Australia will only match orders where the transaction is entered into at a price (at the time of execution) that is:
 - at a valid price step (i.e. tick size) that is both above the best available bid and below the best available offer; or
 - at the midpoint of the best available bid and best available offer (where midpoint = (best available bid + best available offer) ÷ 2).

The best available bid and best available offer are the highest pre-trade transparent bid and lowest pre-trade transparent offer available across all pre-trade transparent order books of licensed markets (also known as the national best bid and offer or NBBO). CLSA will not use any non-pre-trade transparent (e.g. hidden orders) in calculating the NBBO.

4 Order Types

For orders with the crossing indicator set to either “Do Not Cross” or “Can Cross”, ALP Australia will pass these orders through to ASX or Cboe. As such, the order types accepted by ALP Australia are the same as those that are supported by ASX or Cboe. None of the order details are changed as a part of passing an order through to the exchange.

Orders with the crossing indicator set to ‘Cross Only’ are not passed to ASX/Cboe. The list of accepted order types for ‘Cross Only’ orders are as follows:

Limit	Orders may cross within the limit price
Market	Orders may cross at any permitted price
Immediate Or Cancel	Any unfilled quantity will be rejected immediately after order receipt.

5 User Treatment

ALP Australia processes orders from all sources in the same manner. ALP Australia implements price / time priority matching only. There is no preferential treatment afforded to any individual user or user tier group.

6 Anonymity

All orders in ALP Australia are anonymous. ALP Australia's IOB cannot be viewed by any trading users, either internally to CLSA or externally. Orders within ALP Australia can only be viewed by compliance staff for compliance monitoring, and by technical support staff for technical support and maintenance. There are no indications of interest ("IOI") published based on orders within ALP Australia.

7 CLSA Principal Flow

Currently, Principal order flow does not make up the order book composition of ALP Australia.

8 Liquidity Providers

Liquidity providers are contemplated under 'Designated Tier Value' "L" as displayed in the User Tier Settings' table under section 2.2 of this document.

CLSA categorises a liquidity provider as an '*institutional professional investor which engages in high frequency trading*'.

There are no commitments imposed by CLSA on this user group to provide quotes across a specified period, minimum order sizes etc.

Liquidity providers are also not given any favourable benefits such as lowers fees, order priority, favourable prices, outcomes or access to order types not available to other users of ALP Australia.

9 Fees

There are no additional fees charged to clients for accessing ALP Australia, other than standard brokerage commission. ALP Australia is provided to clients as a free service to improve execution performance.

10 Crossing Suspension

The crossing function of ALP Australia can be manually enabled or disabled at any time, by the front office production support team. While the crossing function is disabled, ALP Australia will continue to accept orders, and store them in ALP Australia's IOB . If the crossing indicator is set to "Can Cross" or "Do Not Cross", the order will be sent to the exchange. However, ALP Australia will not cross any orders while the crossing is disabled, and subsequently it will not send any trade reports to the exchange.

This function is intended to be used by CLSA production support staff as a safety measure in exceptional circumstances only. Examples of these circumstances are:

- Technical issues at the ASX or Cboe which prevent securities trading; and
- Technical issues with CLSA's connection to either the ASX or Cboe which prevent securities trading and sending trade reports.

Crossing will resume as normal, and any orders stored in ALP Australia IOB may be crossed, when the crossing function is manually re-enabled.

11 Crossed Trade Indicator

For clients which trade with CLSA electronically using FIX protocol, any trades on their orders that have been matched in ALP Australia, will be indicated on the execution report messages sent to the client.

Trade matched in ALP Australia FIX tag 30 (LastMkt) = "2311"

This will allow clients to readily identify the executing venue of each trade.

12 Resilience

ALP Australia runs on two servers located in two different data centers in Sydney. Source systems connect to ALP Australia via a virtual IP address, which will always point to the primary instance. If the primary instance fails, the virtual IP will point source systems to the backup server running in the other data center.

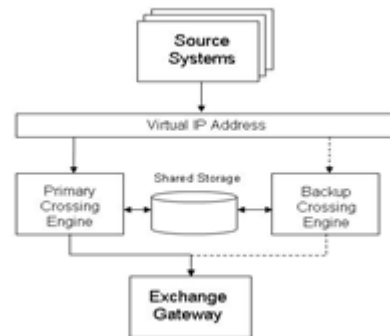

13 Outages

If technical or other system issues materially affect the efficiency of or proper functioning of ALP Australia. Orders will be treated as follows:

i) *Orders resting in ALP Australia at the time of an outage:*

ALP Australia supports 'shadow posting'. This means a crossable order is shadowed in ALP Australia but also posted on ASX or Cboe. If the outage scenario relates to ALP Australia matching logic, orders will continue to participate in ASX or Cboe, just that they will not be crossed in ALP Australia.

However, if ALP Australia is completely non-responsive, then manual intervention will be required to re-route the order to ASX or Cboe.

ii) *Clients instructing to trade on ALP Australia only.*

CLSA will inform impacted clients. Clients will have the optionality to leave orders resting on the ALP Australia IOB or, cancel their orders.

iii) *Clients executing on all venues.*

Orders will be 'shadow posted'. If the outage relates to an ALP Australia problem with the matching logic, ALP Australia will act as a 'pass through' gateway to ASX and Cboe order books.

If ALP Australia is non-responsive CLSA will manually re-route these orders to ASX and Cboe in accordance with client instructions.

CLSA will also make contact with all impacted clients to provide the following information:

- (a) A description of the effect of the technical or other system issues;
- (b) How the technical or other system issues are being managed;
- (c) Any alternative arrangements for users' orders that have been put in place by CLSA while the technical or other systems issues persist; and
- (d) When the technical or other system issues have been resolved,

As soon as practicable after the technical or other system issue arises, or the issue is resolved, as applicable.

14 Disclosures

ALP Australia allows clients to cancel orders at any time prior to execution.

ALP Australia allows clients to specify a minimum execution quantity of their choice.

All ALP Australia orders are 'good for the day' only. Any open, unexecuted order will be purged at the end of each trading day.

CLSA operates ALP Australia in strict compliance with the requirements set out in Chapter 5A of the ASIC Market Integrity Rules (Securities Markets) 2017 which governs the operation of crossing systems in Australia.

Each external crossing system that CLSA is connected to, and may route orders to, are operated and managed by the operator as set out on the "Crossing systems registered with ASIC" website: (<https://asic.gov.au/regulatory-resources/markets/market-structure/crossing-systems-registered-with-asic/>) and not by CLSA. For additional information about any external crossing systems, please contact the relevant operator of the ASIC registered crossing system.

15 Other Dealing Matters

15.1 Fair and orderly operation

CLSA aims to provide a fair and orderly platform for operation of ALP Australia. ALP Australia is subject to CLSA Group Policies relating to Information Technology and Compliance.

15.2 Order confidentiality

ALP Australia does not publish IOI or any information regarding its IOB to any CLSA trading desk or other market participant.

16 Risk Disclosure Relating to the use of the crossing system

On occasion there may be a time delay before the best bid and best ask price of the security is reflected in the crossing system, due to technology or communication delay or interruption related to market data or otherwise. In such an event the price crossed in the crossing system may not reflect the market price in the relevant Exchange.

Where users specify 'Cross Only' as the crossing identifier, there is no assurance given with regards to the liquidity of orders in the crossing system. The liquidity of the crossing system may be less favorable than the same in the relevant Exchange.

CLSA has taken reasonable steps to protect the integrity and confidentiality of orders in CLSA's crossing system to a level we consider appropriate, however leakage of trading information may occur beyond our reasonable level of system and internal control.

This document is not intended to have any force of law, be it in contract or tort. This document also does not seek to introduce, and should not be seen as imposing, any obligation or liabilities between you and CLSA beyond those defined in our terms of business or contractual agreement. This document/communication is for information purposes only. ALP Australia is provided on an 'as is' basis and there is no warranty, representation or other assurance in connection with the ALP Australia or external Crossing Systems, including as to availability, accuracy, completeness, results, functionality, reliability, performance, timeliness, non-infringement, suitability, quality, merchantability, fitness for a particular purpose or otherwise. Also there is no warranty that access and/or use of the ALP Australia or an external Crossing System will be uninterrupted or error-free.